

AdvanTex® Treatment Systems

AX20 and AX-RT Residential Treatment Systems Overview

Introduction

Orenco's residential AdvanTex AX20 and AX-RT Treatment Systems are a robust, reliable, and sustainable technology for onsite treatment of wastewater. The heart of our AdvanTex Treatment Systems is the compact and efficient AdvanTex filter – a proven, low-maintenance, highly reliable recirculating packed bed filter comprised of sheets of engineered textile. AdvanTex Treatment Systems works just like a recirculating sand filter or recirculating gravel filter: a reliable, proven technology that Orenco's engineers have helped to perfect over the past 30 years. While the treatment process is similar, the proprietary AdvanTex Treatment System is more efficient. In fact, the textile has about five times greater surface area for biological breakdown of wastewater components than an equivalent volume of sand, so the AdvanTex System is more compact.

Orenco Systems has been researching, designing, testing, and selling a variety of textile filters for more than a decade. About 46,000 AdvanTex textile filters have been installed throughout the United States, Canada, Australasia, and Europe on sites ranging from federal demonstration projects to university testing facilities, single-family homes, commercial properties, and community systems.

Applications

AdvanTex Treatment Systems are ideal for ...

- Single-family homes
- Small commercial properties
- New construction, repairs
- Tight lots, other site constraints
- Poor soils, shallow bury
- Stringent permit requirements
- Nitrogen reduction, disinfection
- Surface discharge



AdvanTex AX-RT Treatment Unit



AdvanTex AX20 Treatment Unit

All product and performance assertions are based on proper design, installation, operation, and maintenance according to Orenco's current published documentation.

Treatment Methodology

An AdvanTex Treatment System includes an AdvanTex AX20 or AX-RT Treatment Unit, a processing tank, and a control panel with a programmable dosing timer. In the AdvanTex treatment process, filtered wastewater from the clear zone in the processing tank is pumped to a distribution manifold in the treatment unit. The effluent percolates down through the textile media, where aerobic treatment occurs. The textile media's complex fiber structure provides tremendous water-holding capacity and offers an extremely large surface area for biomass attachment. A percentage of the treated effluent is recirculated for dilution and additional treatment, and the remaining treated effluent is discharged for dispersal.

System Performance

Within a few days of the system's start-up, a visible biological film normally develops on the filter; CBOD_5 and TSS reductions occur almost immediately. AdvanTex Treatment Systems treat residential-strength waste to better than "secondary" standards, providing consistent, reliable wastewater treatment even during peak flow conditions – unlike other wastewater treatment technologies. The system discharges small amounts of treated wastewater, regularly, throughout the day. The treated effluent can be used for drip or subsurface irrigation, or discharged to shallow, inconspicuous trenches. It can also be discharged to fine-grained polishing filters for coliform removal and water reuse.

Third-Party Performance Verification

AdvanTex Treatment Systems are listed to NSF/ANSI Standards 40 and 245 for Class I Systems. Third-party performance testing recorded a maximum 30-day arithmetic mean of 8 mg/L for CBOD_5 and 6 mg/L for suspended solids. Over a six-month course of evaluation, the average effluent CBOD_5 was 5 mg/L, and the average effluent suspended solids was 4 mg/L (NSF Final Report, April 2002).

System Benefits

AdvanTex Systems have a small footprint and low lifetime costs for a number of reasons. Loading rates for AdvanTex Treatment Systems are typically 5-20 times higher than for other packed bed filters. Because of this, reductions in drainfield size are often permitted with AdvanTex Treatment Systems. Moreover, textile is lightweight, making it ideal for prepackaging and shipping, which simplifies installation and reduces costs.

Also, the pumps in an AdvanTex System typically run just 30-60 minutes per day, so they use very little power ... an average of \$1.80-5.00 per month (based on the national average of ten cents per kilowatt hour). Compare that to power costs of up to \$30-\$60 per month for many activated-sludge aerobic treatment units.

The low power usage, reuse-quality effluent, and small footprint of AdvanTex Systems are significant enough to qualify AX20 and AX-RT systems for LEED credits. For example, the Audubon Center at Debs Park in Los Angeles uses several AdvanTex AX20 units and earned the nation's first Platinum LEED rating.

System Operation and Maintenance

AdvanTex Treatment Systems are easy to service and clean. Like most advanced technologies, AdvanTex Treatment Systems require regular maintenance. As a condition of warranty, property owners must purchase a service contract from a certified third party provider.

AdvanTex Treatment Systems come standard with a VeriComm® telemetry control panel with a Web-based monitoring system, supervised by the System's service provider. Alarm notifications are automatically sent to the service provider's e-mail capable device. Messages are resent until the condition has been cleared. As a back-up, the VeriComm control panel also has an audible alarm. And the System is sized to allow for a minimum of 24 hours of wastewater storage (at average daily flows). That means an operator can provide service to the system during normal working hours, regardless of when an alarm occurs.

Treatment System Views — AX20

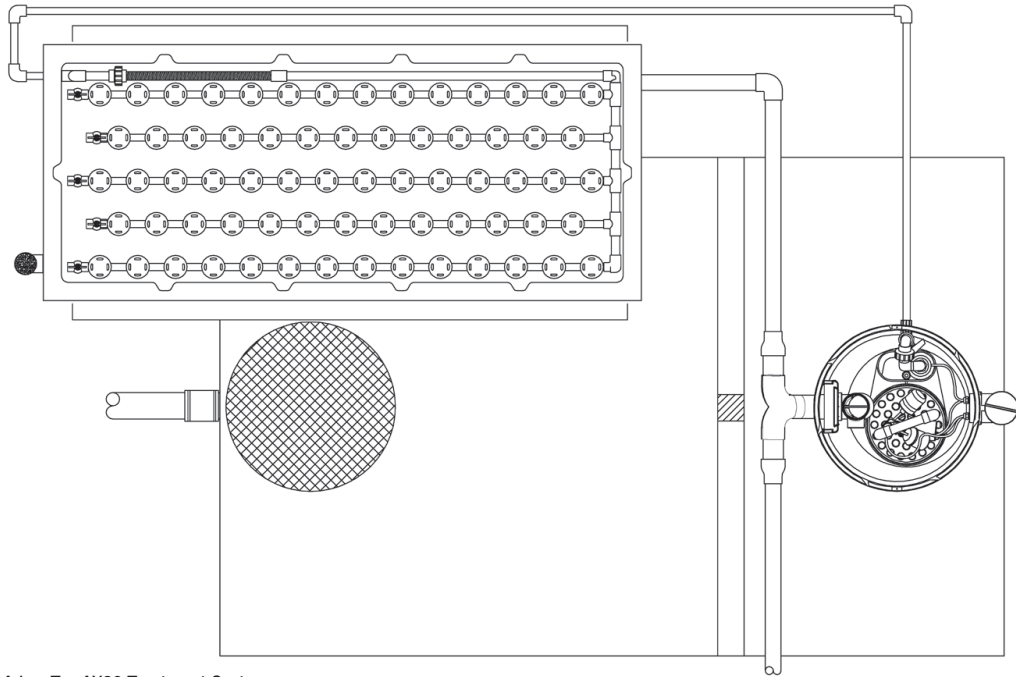

Top view of a typical AdvanTex AX20 Treatment System

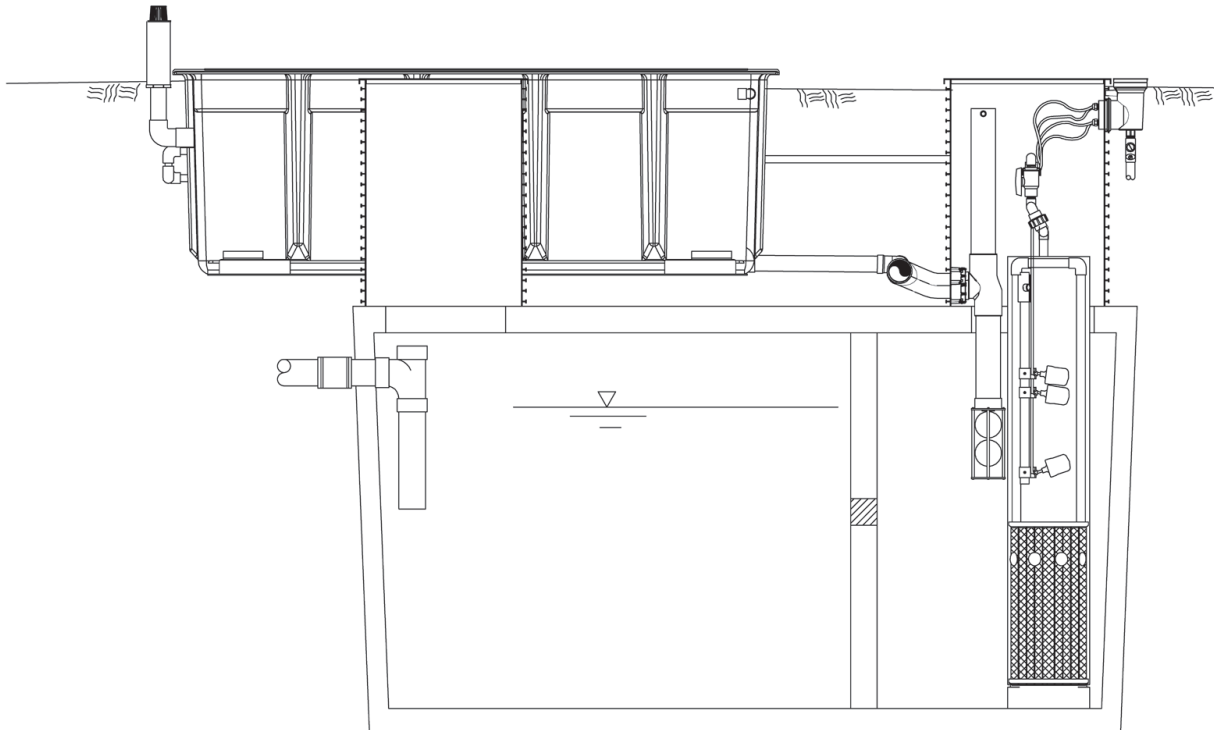

Side view of a typical AdvanTex AX20 Treatment System

Treatment System Views — AX-RT

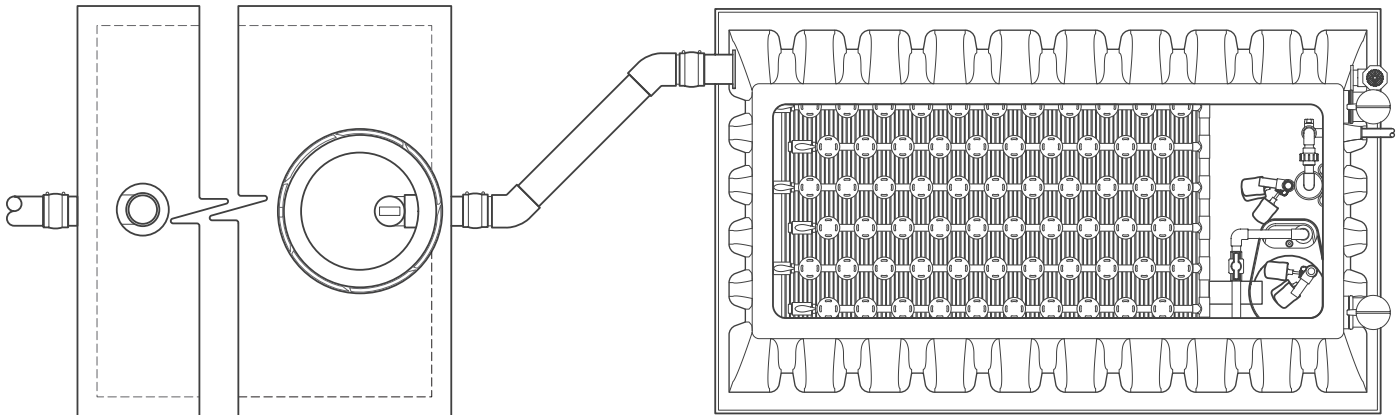

Top view of a typical AdvanTex AX-RT Treatment System (AX20-RT with pump discharge shown)

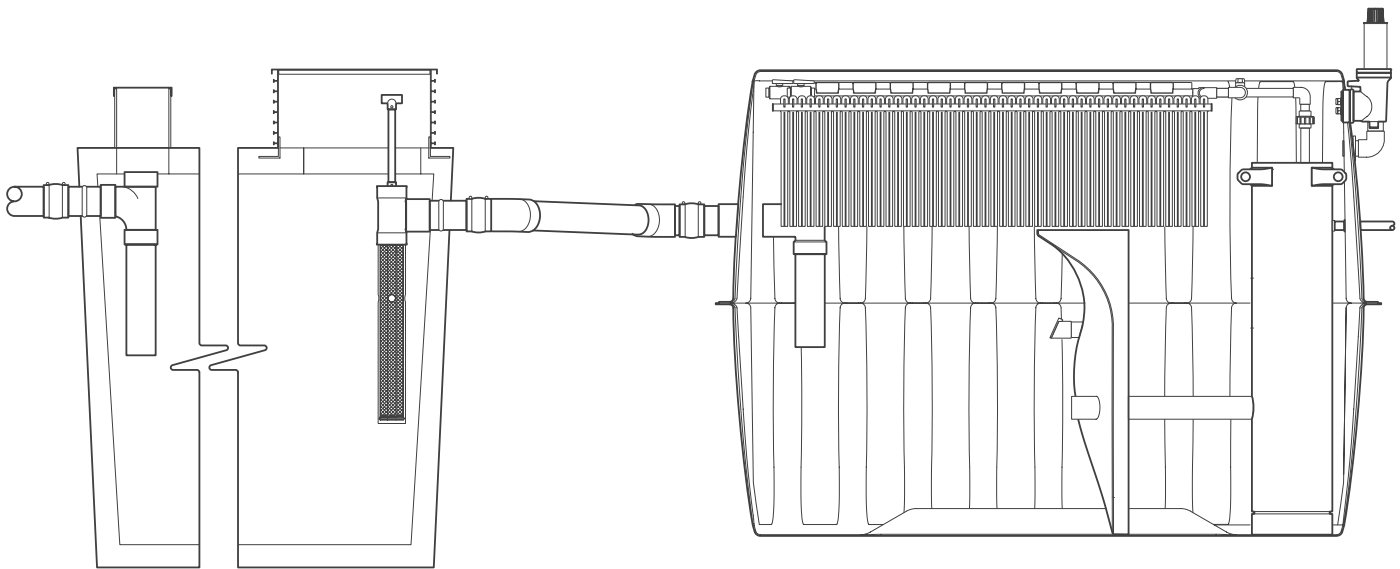

Side view of a typical AdvanTex AX-RT Treatment System (AX20-RT with pump discharge shown)



AdvanTex Treatment Systems are listed to NSF/ANSI Standards 40 and 245 for Class I Systems.