

Orenco AdvanTex® AX20 Residential Treatment Massachusetts

Introduction

This design criteria covers Orenco's AdvanTex AX20 Wastewater Treatment Systems used for single-family residential treatment applications in Massachusetts.

System Description

The AdvanTex AX20 Wastewater Treatment System is a multiple-pass, packed-bed aerobic wastewater treatment system specifically designed and engineered for long-term processing of residential strength wastewater. The treatment media sheets are an engineered textile, which has an extremely high void capacity, moisture-holding capacity, and surface area per unit volume. Consequently, AdvanTex treatment systems are capable of processing residential strength wastewater to better than secondary standards. Figure 1 shows a basic overview of the AX20 Wastewater Treatment System.

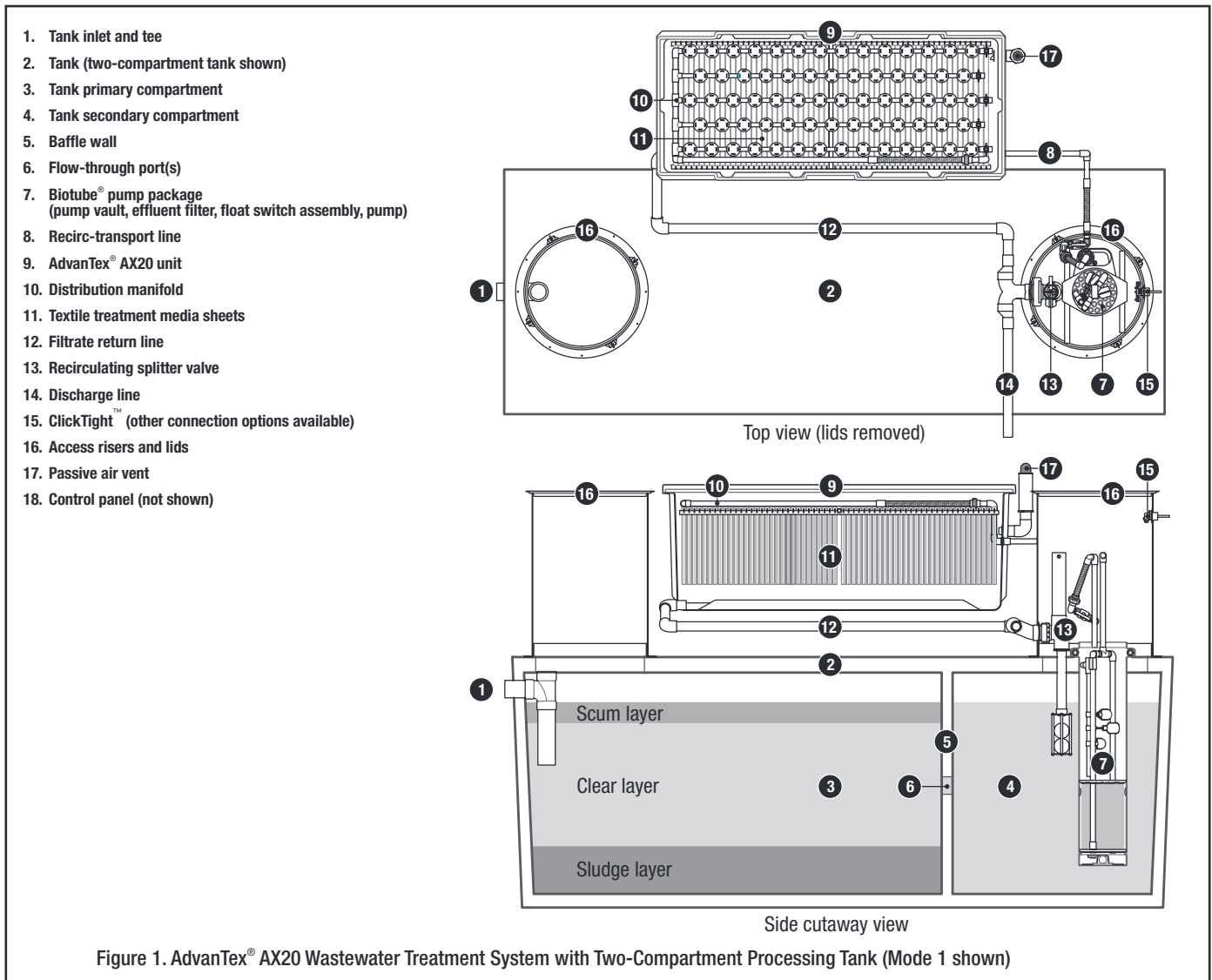

Treatment Process

Here's how a standard AdvanTex AX20 configuration works. Raw sewage enters the two-compartment processing tank through its inlet tee. In the first compartment, the raw sewage separates into three distinct zones: a scum layer, a clear layer, and a sludge layer. One or more flow-through ports in the tank's baffle wall allows effluent from the clear layer to flow into the second compartment of the tank. The Biotube® pump package in the second compartment pumps filtered effluent to a distribution manifold inside the AX20 unit. Effluent percolates down through the textile media sheets and collects in the bottom of the unit. The treated effluent flows out of the unit through the filtrate return line, which returns the treated effluent to the recirculating splitter valve (RSV). The RSV automatically splits or diverts the flow between the processing tank and final discharge. The RSV also controls the liquid level within the processing tank. During extended periods of no flow, 100% of the treated filtrate effluent is returned to the processing tank. Residential AdvanTex AX20 units have a passive vent system and do not require the use of a fan.

System Selection

Models and Configurations

The AdvanTex AX20 Treatment System can be configured in several modes. Mode 1 (shown in Figure 2a) is the operating configuration used most frequently. In Mode 1, the filtrate recirculates through the second compartment of the processing tank. In Mode 3 (a specialty mode, shown in Figure 2b), a portion or all of the filtrate may be recirculated through the primary chamber of the tank to enhance nutrient removal. Some of the systems in Mode 1 incorporate two tanks: a primary tank and a recirculation tank. In the primary tank, sludge and scum are separated from liquid effluent, which then flows into a separate recirculation tank, into which the AdvanTex filtrate is recirculated (shown in Figure 2c). AdvanTex AX20 treatment system drawings showing treatment mode and discharge options are available from Orenco.

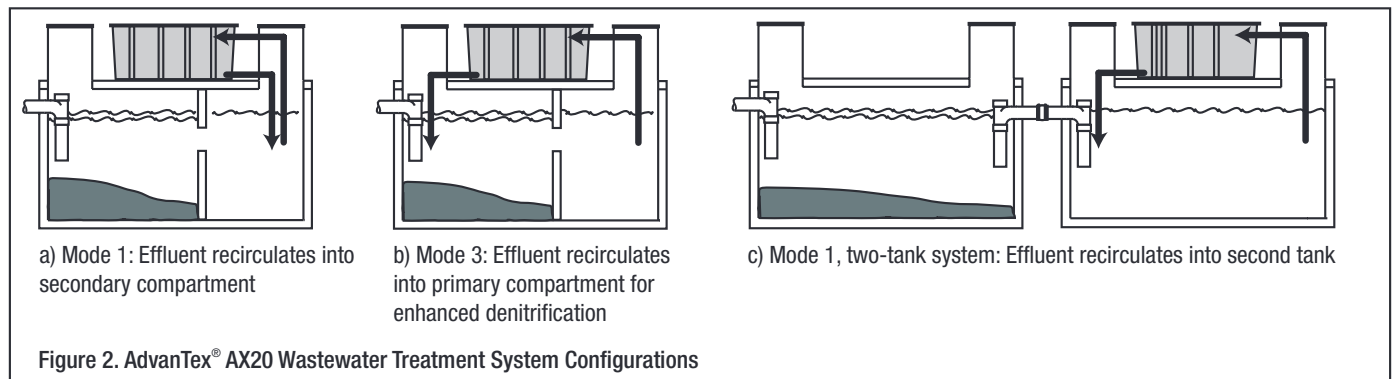

Required Tankage and AX20 Units

The following tables summarize the required tankage and required number of AX20 units based on occupancy and maximum design flow. Table 1 is for systems using a single processing tank. Table 2 is for systems using separate processing and recirculation (recirc) tanks. Requirements assume residential peak weekly average flows (Q_{pwa}) are typically two times normal average daily flows (Q_d), or $Q_{pwa} = 2Q_d$. It's also assumed that peak weekly average flows meet typical regulations governing flow-to-bedroom ratios.

Table 1. Required Tankage and Number of AX20 Units: Systems Using Single Processing Tank

Number of Bedrooms*	Maximum Occupants [†]	Minimum Processing Tank Size, gal (L) [‡]	AX20 Units**
4 or fewer	8	1500 (5678)	1
5	10	2000 (7571)	1
6	12	3000 (11,356)	2

* Use bedrooms as default sizing criteria. (Jurisdictions vary greatly on calculations of gal or L per bedroom.) Contact Orenco for homes with more than six bedrooms.

[†] Systems for homes with occupancies greater than eight require a design with multiple units based on a minimum of 2.5ft² (0.2m²) of surface loading area per capita.

[‡] Processing tank includes primary (septic) and secondary (recirculation) compartments.

** The nominal application rate is 30gpd/ft² (1222L/m²/day).

Required Tankage and AX20 Units, cont.

Table 2. Required Tankage and Number of AX20 Units: Systems Using Separate Processing and Recirc Tanks

Number of Bedrooms*	Maximum Occupants†	Minimum Processing Tank Size, gal (L)‡	Minimum Recirc Tank Size, gal (L)‡	AX20 Units**
4 or fewer	8	1500 (5678)	1000 (3785)	1
5	10	2000 (7571)	1000 (3785)	1
6	12	3000 (11,356)	1000 (3785)	2

* Use bedrooms as default sizing criteria. (Jurisdictions vary greatly on calculations of gal or L per bedroom.) Contact Orenco for homes with more than six bedrooms.

† Systems for homes with occupancies greater than eight require a design with multiple units based on a minimum of 2.5ft² (0.2m²) of surface loading area per capita.

‡ The 1000gal (3785L) minimum is due to float settings/reserve requirements.

** The nominal application rate is 30gpd/ft² (1222L/m²/day).

System Requirements

Residential-Strength Wastewater

Residential wastewater must meet the criteria in Table 3, below. Contact Orenco or your AdvanTex dealer for larger system designs.

Table 3. Influent Characteristics for Residential-Strength Wastewater*

Characteristic	Average, mg/L	Weekly Peak, mg/L	Rarely Exceed, mg/L
cBOD ₅	130	200	300
TSS	40	60	150
TKN	65	75	150
FOG	20	25	25

* Maximum allowable wastewater strength pumped to an AdvanTex Treatment System is "residential-strength wastewater." Residential-strength wastewater is defined as primary sewage effluent from a septic tank that does not exceed the above parameters.

Processing Tank

Homes with as many as four bedrooms require, at minimum, a two-compartment, 1500gal (5678L) nominal-volume tank with flow-through port(s) equaling a minimum flow-through area of not less than 12in² (7742mm²) at 60% to 70% of the lowest normal liquid level. In larger residential systems, the first compartment should be sized at approximately 66% to 75% of the total processing tank volume. Table 1 defines the minimum required tankage for residential AdvanTex applications (unless otherwise approved by both Orenco and the local regulatory body).

All tanks must meet Orenco's minimum structural requirements, be completely watertight, and pass a watertightness test (including the riser/tank connection). For detailed specifications, see structural and watertightness criteria in [Orenco Effluent Sewer Equipment Specifications, NSP-EFS-SPEC-1](#), and [Acknowledgment of Minimum Tank Requirements – AX20, SLD-TNK-SPEC-1](#), as well as the tank specifications checklist in [Concrete Tank Questionnaire, NCL-TNK-TNK-1](#).

Recirculation Pump

The integrated treatment package includes an Orenco 4in (100mm) submersible effluent pump, a Biotube pump vault, a float switch assembly with float switches, a hose and valve assembly, a splice box or Orenco ClickTight™, and a control panel.

AdvanTex Control Systems

The method in which the effluent is loaded onto the AdvanTex textile filter is critical to the success of the AdvanTex Treatment System. Over the past three decades, timer-controlled applications have proven to play an essential role in optimizing the performance of both fixed- and suspended-growth biological systems. A timer-controlled pump in the processing tank periodically doses effluent to a distribution system on top of the AdvanTex filter. Each time the filter is dosed, effluent percolates through the filter media and is treated by naturally occurring microorganisms that populate the filter. During periods of high flow, a timer-override float will temporarily modify the timer settings to process the additional flow. Conversely, during periods of low flow, the timer settings can be modified to reduce loading onto the AdvanTex filter. Orenco offers two timed-dose control panels with the AdvanTex Treatment System.

AdvanTex Control Systems, cont.

Orenco's VeriComm® (VCOM) remote telemetry control panels and web-based monitoring system are incorporated into all AdvanTex Treatment System standard equipment packages. VCOM gives wastewater system operators and maintenance organizations the ability to remotely monitor and control each individual system's performance. There are several additional operational benefits associated with telemetry-based controls, including advanced control logic – functions that activate in the event of component malfunction to diagnose the system using pre-established trend data and, if necessary, modify the operation of the system until it can be serviced. VCOM also provides additional alert and alarm functions to notify the operator/designer in the event that trend data indicate potential problem conditions (for example, high flows or frequent alarms).

In some markets, Orenco offers its Most Versatile Panel (MVP) series as an alternative to VCOM panels. MVP control panels include an easy-to-use programmable logic unit that incorporates many timing and logic functions. The units have built-in screens that show time and date, elapsed pump run times, pump cycle counts, high-level alarm and override cycle counts, and low-level alarm counts, as well as power fault information and operating hours. In addition, there are separate screens that show the status of the panel's digital inputs and outputs. These features give operators and maintenance providers the ability to monitor individual systems on site. Alarm events activate the panel's audible and visual alarms.

Discharge Equipment

There are two discharge options: gravity and pump. When discharging by pump, an Orenco pump basin can be used. Alternatively, some designs may call for pumping out of a tank (see Figure 3).

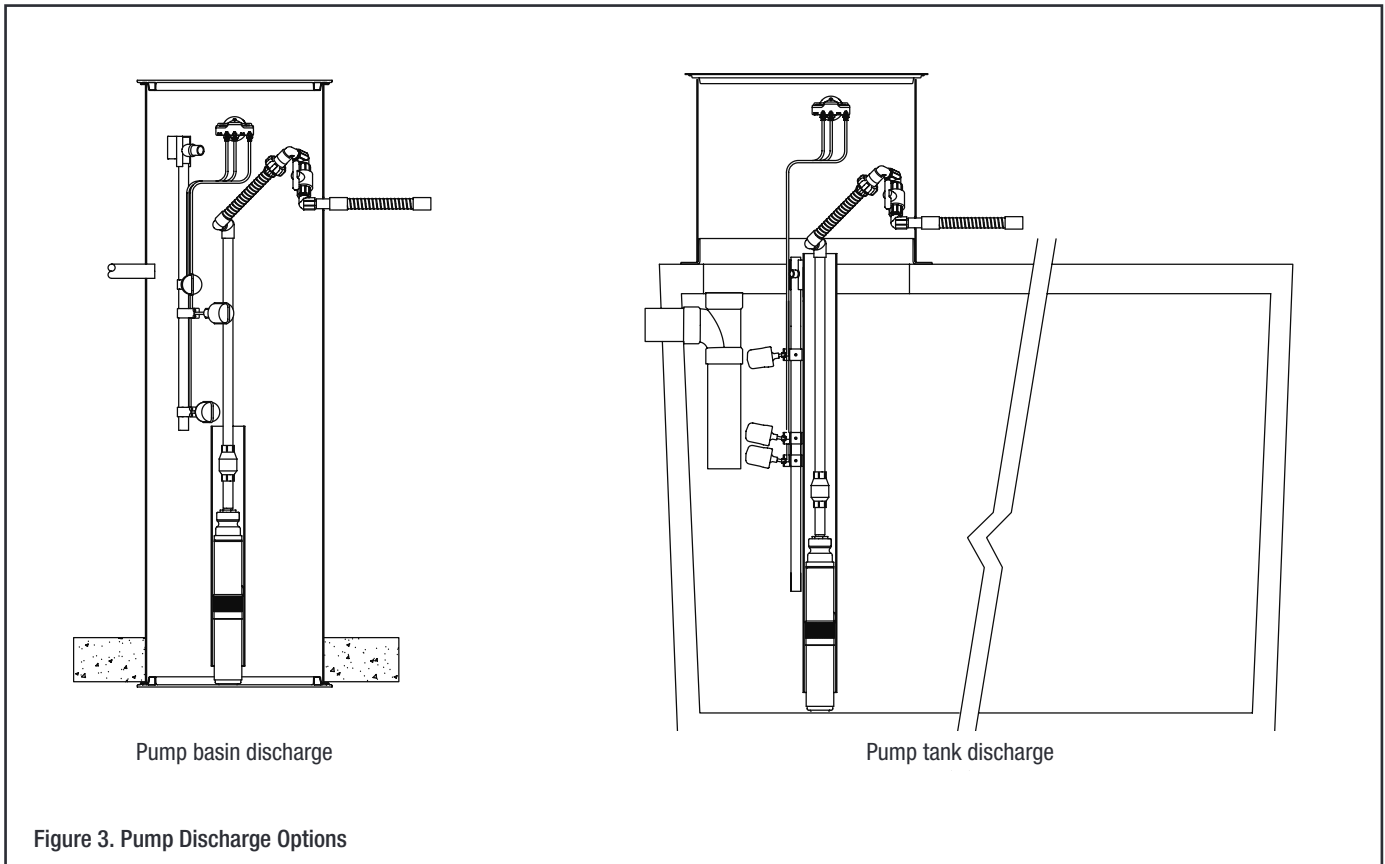

All tanks must meet Orenco's minimum structural requirements, be completely watertight, and pass a watertightness test (including the riser/tank connection). For detailed specifications, see structural and watertightness criteria in [Orenco Effluent Sewer Equipment Specifications, NSP-EFS-SPEC-1](#), and [Acknowledgment of Minimum Tank Requirements – AX20, SLD-TNK-SPEC-1](#), as well as the tank specifications checklist in [Concrete Tank Questionnaire, NCL-TNK-TNK-1](#).

Design Loading Rates

Orenco's suggested design loading rates are based on typical per capita flow rates (50 to 60gal/day/person or 189 to 227L/day/person) and average strength characteristics expected from residential-type installations, as shown in Table 3. Performance is a function of the expected typical loads with periodic weekly highs. Typically, the daily mass loading is based on the expected daily flows and actual strength. Figure 4 shows periodic peak loading capacity at a 95% confidence level. If the loading rate (or mass load) needs to be reduced to meet discharge limits, additional modular units are easily added.

AdvanTex Treatment Systems are listed to NSF/ANSI Standards 40 and 245 for Class I Systems.

Typical Effluent Quality

Effluent quality is dependent on a number of factors, including influent characteristics and loading rates. Figure 4 shows third-party, NSF/ANSI Standard 40 testing results. The results demonstrate that low-to-moderate loading rates typically produce cBOD₅ and TSS of <5mg/L, while higher loading rates produce cBOD₅ and TSS in the range of 15-25mg/L. Field testing of systems in real-world conditions shows similar results, with cBOD₅ and TSS of <10 mg/L. (See [AdvanTex Treatment Systems Performance Summary, AHO-ATX-PERF-1](#).)

Nitrogen reduction in Mode 1 will typically exceed 60%, with total nitrogen in the filtrate ranging between approximately 25 and 35mg/L. In Mode 3, nitrogen reduction can reach 70% or better, depending on wastewater strength and other characteristics like fats, oils, and grease, as well as pH, and alkalinity concentrations. Nitrification can be inhibited if the buffering capacity (alkalinity) of the wastewater is too low. On a theoretical basis, 7.14mg/L of alkalinity as CaCO₃ is needed to nitrify 1mg/L of NH₄⁺.

Residual Head Pressures

A residual pressure of 5ft (1.5m) is used to determine the initial timed-dosing settings. (Residual pressure may vary depending on system hydraulics and/or special treatment requirements.) Consulting with Orenco is required when the residual pressure dosing falls outside the typical range of 3 to 6ft (0.9 to 1.8m).

Recirculation Ratios and Timer Settings

The AdvanTex Treatment System's initial timer settings should be established based on the expected average daily flow and a 4:1 recirculation ratio (filter recirculation ratio). If flows vary significantly from expected flows, timer settings can easily be recalculated and adjusted. See Appendix 1, "AX20 Timer Settings Worksheet," in [AdvanTex O&M Manual Part 1: Start-Up and Routine Maintenance, AIM-OM-ATX-1](#), for more information.

Surge and Reserve Volumes

The surge volume is the volume between the normal low liquid level and the override-timer float. The normal low liquid level is the level at which 100% of the filtrate returns to the tank. For most residential installations, the low liquid level will be approximately 5 to 6in (127 to 152mm) below the top of the RSV cage. In typical residential applications, the recommended surge volume is approximately 150 to 250gal (568 to 946L). The actual surge volume used should be approximately 50% to 100% of the actual average daily flow. Refer to [AdvanTex AX20 Installation Manual, NIM-ATX-AX-1](#), for details.

Following the tank sizing guidelines found in Table 1 and Table 2, all AX20 designs provide emergency storage capacity above the working level equal to the daily design flow of the system.

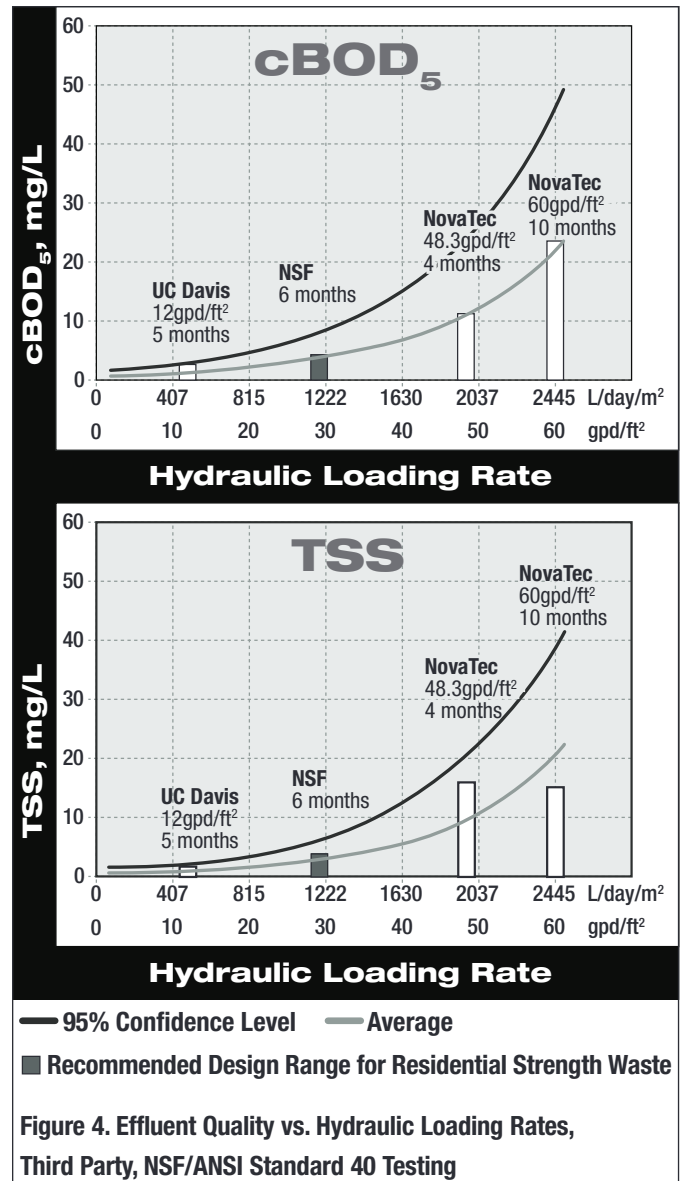

Figure 4. Effluent Quality vs. Hydraulic Loading Rates, Third Party, NSF/ANSI Standard 40 Testing

Surge and Reserve Volumes, cont.

Power Outage

During a power outage, water usage will be significantly reduced because water heaters, dishwashers, and laundry equipment will not be used. Under these conditions, it is realistic to estimate that water usage will be reduced by 50% to around 125gpd (473L/day). Therefore, in a power outage, the emergency storage capacity available in an AdvanTex system increases to approximately three days' worth of wastewater flow. For power outages lasting no more than one day, the emergency storage capacity of an AdvanTex system is generally adequate.

Mechanical Component Failure

Failure of a pump or electrical component may cause the system to stop operating, requiring some amount of emergency storage volume. With VCOM panels, the VeriComm Monitoring System immediately notifies the service provider and indicates the cause of the alarm once an alarm level is detected. This allows the service provider to bring the right replacement component. MVP panels will immediately activate the local audible and visual alarms once an alarm level is detected. In most cases, no more than one day of emergency storage (250gal or 946L) would be needed for the service provider to respond and get the system running again.

Cold Weather Considerations

AX20 unit lids have an R-6 (RSI-1.1) insulation value. Installing insulation around the sides of the filter units themselves is optional and is done on site, as needed. Other cold weather considerations include standard practices used with most onsite pump systems, such as allowing all lines to drain, insulating processing tank lids, and backfilling risers with pea gravel if frost heave is a concern. The filter vent may need to be extended above the highest level of the snowpack during winter months. Contact Orenco if supplementary options need to be considered.