

Panel Wiring Diagram Model S1 PT RO

Simplex Operation

High Level Alarm: This float activates the alarm light and audible alarm when lifted. The audible alarm may be silenced by pressing the illuminated PUSH TO SILENCE button on the front of the control panel. The alarm light will remain on until the float is lowered.

Timer Override On & Off: This float turns on the pump when lifted and off when lowered.

Timer On & Off: This float turns off the programmable timer when lowered. When this float is lifted the timer will be restarted. Note: The timer will start with its off cycle.

Redundant Off & Low Level Alarm: This float turns off the pump when lowered. This float is a secondary off float which will operate if the Timer On & Off float fails. Pumping will be disabled in both the automatic and manual modes. This float also activates the alarm light and audible alarm. The audible alarm may be silenced by pressing the illuminated PUSH TO SILENCE button on the front of the control panel. The alarm light will remain on until the float is lifted.

Programmable Timer: The timer turns the pump on and off in a pre-set cycle. Note: The timer will start with its off cycle.



814 AIRWAY AVENUE
SUTHERLIN, OREGON
97479-9012

TELEPHONE:
(800) 348-9843
(541) 459-4449

WEBSITE:
www.orenco.com

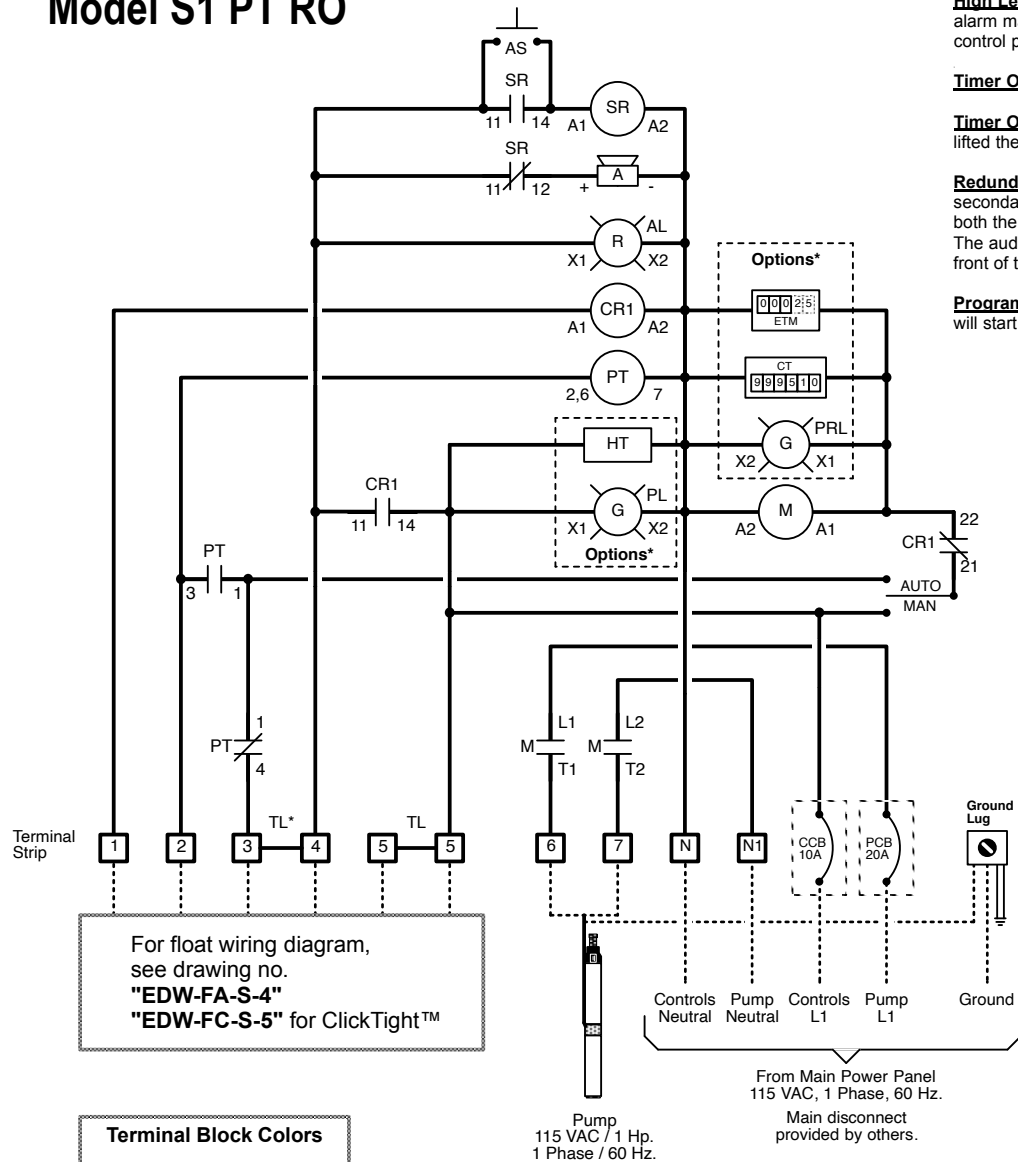

Key

- = Factory Wire
- - - = Field Wire
- · - = Alternate Field Wire
- A = Audio Alarm, 115 VAC
- AL = Alarm Light
- AS = Audio Silence Switch
- CCB = Controls Circuit Breaker
- CR1 = Redundant Off Relay
- M = Motor Contactor
- PCB = Pump Circuit Breaker
- PT = Programmable Timer
- SR = Silence Control Relay
- TL = Terminal Link

*Options

- CT = Cycle Counter
- ETM = Elapsed Time Meter
- HT = Heater
- PL = Power Light
- PRL = Pump Run Light

*Link Rail Placement

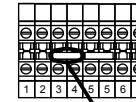

Terminal Link Rail

Removal of the terminal link rail between terminal 3 and 4 will separate the high level alarm and timer override functions.

Power Wiring Options

Two Circuits

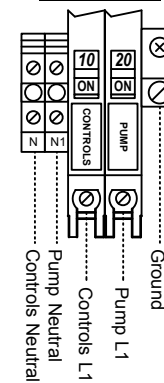

One Circuit

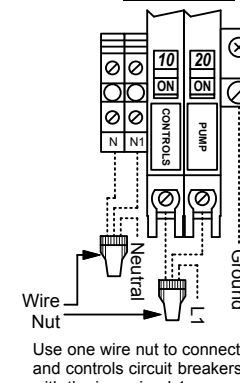

Factory default. Wire as shown.

Use one wire nut to connect the pump and controls circuit breakers together with the incoming L1 power line. Use another wire nut to connect the pump and controls neutral blocks together with the incoming neutral line.

Remote Alarm Connections

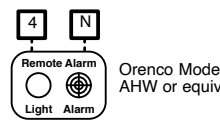

Note: 115VAC signal is present during alarm conditions.