

Fiberglass Basin Installation

Before You Begin

These instructions cover Orenco® Fiberglass (FRP) basins. They do not cover external filter basins or stormwater catch basins. Before you begin the installation, read these instructions and any documents referenced in them. Be sure that the instructions for these products are the most current ones available. The most current instructions are found in our online Document Library at www.orenco.com.

Step 1: Plan Excavation

Step 1a: Determine the depth of the excavation based on the following:

- **Slope** — Follow applicable regulations governing slope. The hole must be deep enough for the inlet line to achieve the required slope to the basin. Orenco recommends a minimum slope of ¼ in. per ft (20 mm per m).
- **Soil type** — If the native soil is rocky or unstable (for example, peat, quick-sand, muck, landfill, or very soft or highly expansive clay), over-excavate the hole by 4 in. (100 mm) and lay a gravel bed in the bottom for stability.
- **Buoyancy** — The basin's buoyancy can be affected by ...
 - ~ High groundwater (including seasonal or flooding)
 - ~ Native soil conditions
 - ~ Fill material
 Buoyancy can be counteracted with an antifoatation collar. If you don't know whether the basin needs an antibuoyancy collar, contact your engineer or designer.
- **Final grade** — The basin's top should be at least 1 in. (25 mm) above final grade.

Step 1b: Determine the width needed for the excavation.

- The hole should extend 6 in. (150 mm) past the basin on all sides.
- If the basin will include a clean-out vent, measure the 6 in. (150 mm) from the outside of the clean-out vent.
- For convenience, basins can share excavations with septic tanks.

Step 1c: Determine the type of bedding and fill materials needed.

- **Bedding** — Use compacted $\leq \frac{3}{4}$ -in. (≤ 19 -mm) rounded gravel, crushed stone, pea gravel, or sand.
- **Fill** — Use native material, $\leq \frac{3}{4}$ -in. (≤ 19 -mm) rounded gravel, crushed stone, pea gravel, or flowable concrete.

Note: Do not use sand for fill material. Do not use native material for fill if it is primarily sand; very soft or highly expansive clay; or if it contains debris, large or sharp rocks ($> \frac{3}{4}$ -in. or 19-mm), peat, or muck.

Step 2: Perform Excavations

Step 2a: Make the excavation for the basin.

- Make the hole at least 6 in. (150 mm) wider than the basin on all sides.
- If the soil is rocky or unstable, over-excavate the depth by 4 in. (100 mm).

Step 2b: Excavate the runs for plumbing and electrical lines.

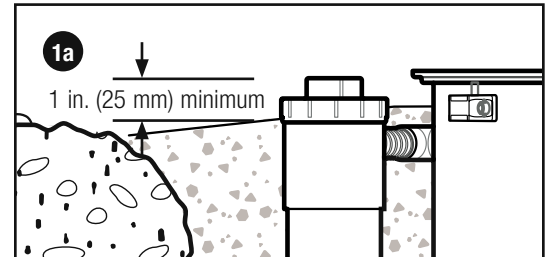

When planning the excavation, remember the basin's top should be a minimum of 1 in. (25 mm) above final grade.

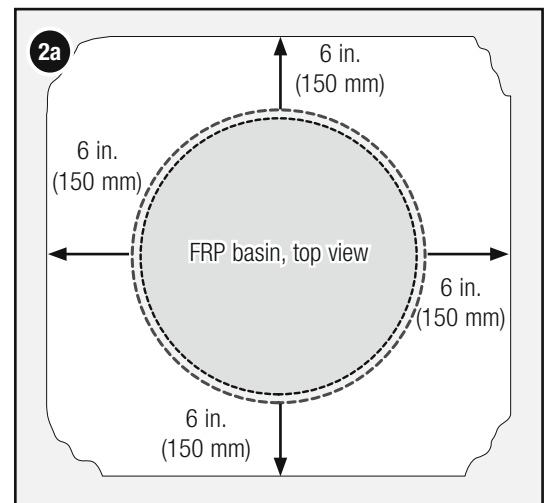

The hole should extend 6 in. (150 mm) past the basin on all sides.

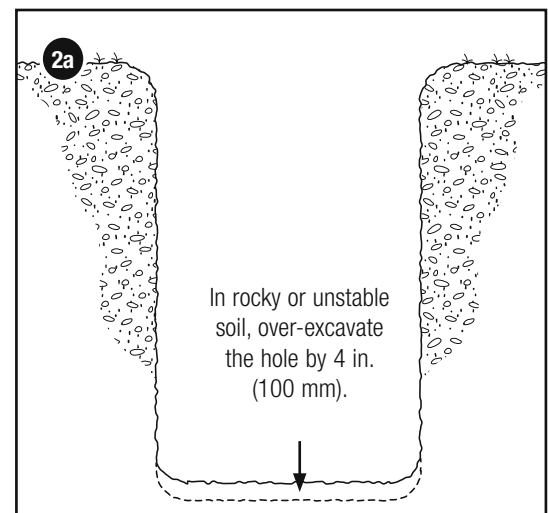

Step 3: Install Grommets and Adapters (If Necessary)

If the splice box grommet or adapter and the discharge grommet haven't been installed, follow this step.

Step 3a: If necessary, install the grommet or adapter for the splice box.

- For detailed instructions, see NIN-SB-SBEX-1, *External Splice Box (SBEX)*.
- For detailed instructions, see NIN-SB-SB-1, *Internal Splice Box (SB)*.

Step 3b: If necessary, install the discharge grommet.

- For detailed instructions, see NIN-HV-1, *Pump and Discharge Plumbing Installation*.

Step 4: Install Clean-Out Vent Assembly (If Necessary)

If the basin requires a clean-out vent (COV) and it hasn't been installed, perform the COV installation.

Step 4a: If necessary, drill the holes for the COV and install the grommets.

- For detailed instructions, see NIN-RLA-RR-1, *Riser Installation*.

Step 4b: Install the supplied elbow in the grommeted COV hole.

Step 4c: Calculate the required height for the COV inlet tee.

Step 4d: Cut two sections of installer-supplied, 4-in. (100-mm) PVC pipe to the correct lengths for meeting the basin transfer line and keeping the clean-out level with the top of the basin.

Step 4e: Dry fit the pipe sections to the inlet tee and clean-out, and mount the assembly on the elbow.

Step 4f: If the inlet tee and clean-out are at the right heights, disassemble the pieces, glue them back together, and glue the assembly into the elbow.

Step 5: Place Bed (If Necessary), Set Basin

Step 5a: If the hole depth has been over-excavated, place and compact a 4-in. (100-mm) bed of aggregate or pea gravel in the excavation before setting the basin.

Step 5b: Set the basin in the hole.

- Align the basin correctly for the inlet, outlet, and electrical penetrations.
- Make sure the basin is level.

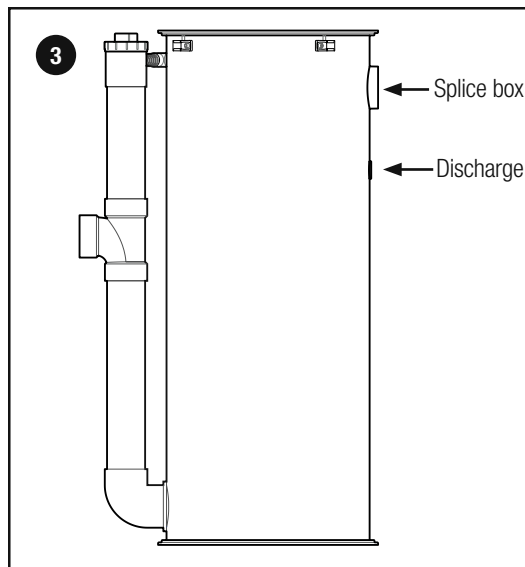

Install the grommets and adapters, if necessary.

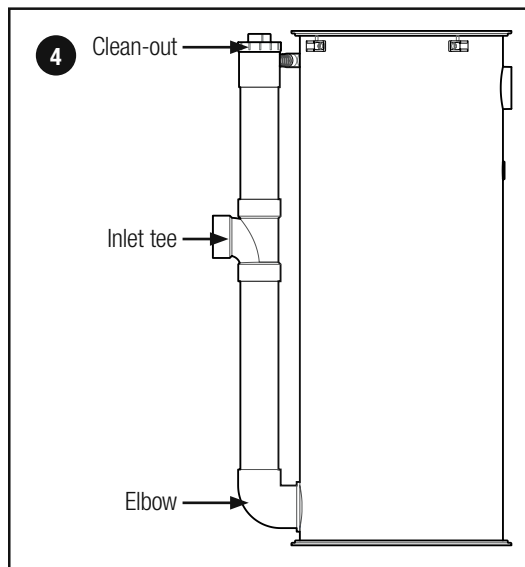

Install the clean-out vent assembly, if necessary.

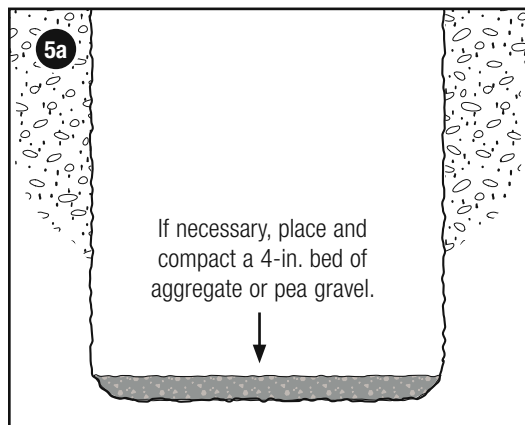

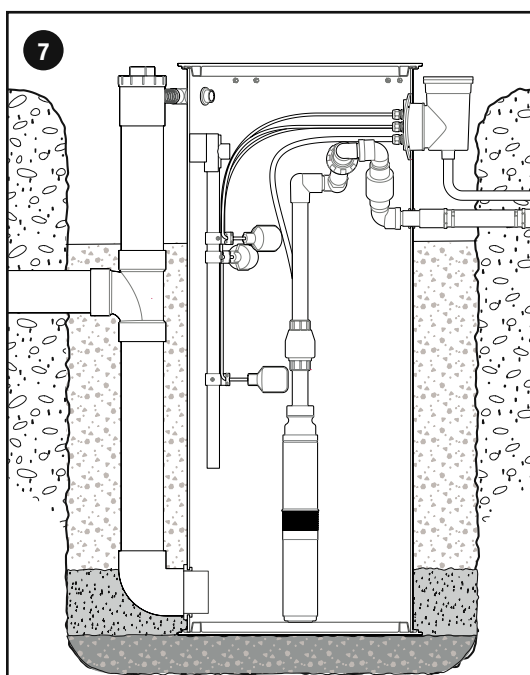
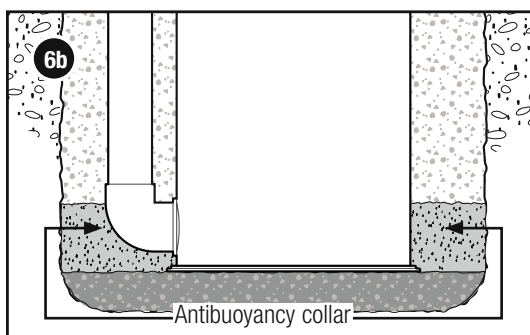
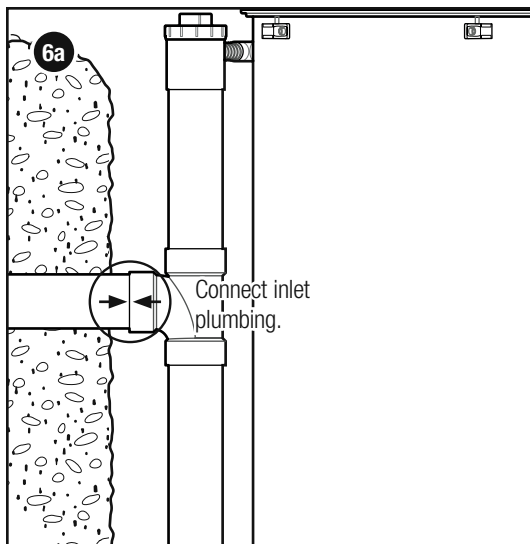

Install the pumping components and make the plumbing and electrical conduit connections.

Step 6: Connect Inlet Plumbing, Perform Partial Backfill

Step 6a: Glue the transfer line into the inlet tee or run the transfer line through the inlet grommet and into the FRP basin.

Step 6b: If the site conditions require it, install an antibuoyancy collar on the basin.

- The collar should extend 6 in. (150 mm) past the basin on all sides and be at least 8 in. (200 mm) thick, measured from the basin's bottom.
- If you don't know whether the basin needs an antibuoyancy collar, contact your engineer or designer.
- If you install an antibuoyancy collar, let the concrete set before backfilling.

Step 6c: Backfill and compact 12-in. (300-mm) lifts of material around the basin, to just below the discharge penetration.

- Do not use native material if it is primarily sand; very soft or highly expansive clay; or if it contains debris, large rocks (> ¾-in. or 19-mm), sharp rocks, peat, or muck; or if frost heave is an issue.
- In these cases, use ≤ ¾-in. (≤ 19 mm) rounded gravel, crushed stone, or pea gravel. This material should be washed, free-flowing, and free of debris.
- Do not backfill with sand.

IMPORTANT: If frost heave is a concern at the site, contact a qualified engineer for recommendations on avoiding frost heave damage to the pump basin before you begin to backfill.

Step 7: Install Components and Make Connections

With the partial backfill completed, install any components that need to be installed. Some or all of the components below may not be required for your installation.

Step 7a: If the splice box hasn't been installed, use the installation instructions included with the splice box to install it:

- For Orenco internal splice boxes, see NIN-SB-SB-1, *Internal Splice Box (SB)*.
- For Orenco external splice boxes, see NIN-SB-SBEX-1, *External Splice Box (SBEX)*.

Step 7b: Install the pump and discharge assembly.

- For 4-in. submersible effluent pumps with HV-style discharge plumbing, see NIN-HV-1, *Pump and Discharge Plumbing Installation*.
- Make sure the pump's voltage and flow rate output (gpm or L/sec) are correct for the system.
- Hand-tighten all fittings. Don't use tools to tighten the connection between the effluent pump and the discharge plumbing assembly or the fittings on the discharge plumbing assembly.

IMPORTANT: DO NOT use the power cord to pick up or lower the pump!

Step 7c: Install the float switch assembly.

- For float switch assemblies, see NIN-MF-1, *Float Switch Assemblies*.

Step 7d: Glue the discharge assembly to the dispersal transport line.

Step 8: Test Watertightness

Step 8a: Fill the basin with water until the liquid level is above the discharge grommet.

Step 8b: Wait at least 30 minutes (or as required by local rules) and then check for any water loss.

Step 8c: Make sure the basin and connections are watertight before proceeding.

Step 9: Perform Final Backfill

Step 9a: Backfill and compact around the basin in 12-in. (300-mm) lifts.

- Follow the fill material and frost heave recommendations from Step 6c.
- Make sure the top of the basin sits at least 1 in. (25 mm) above final grade.
- Make sure the final grade slopes away from the basin.

Step 9b: Secure the basin lid to the basin with the included fasteners.

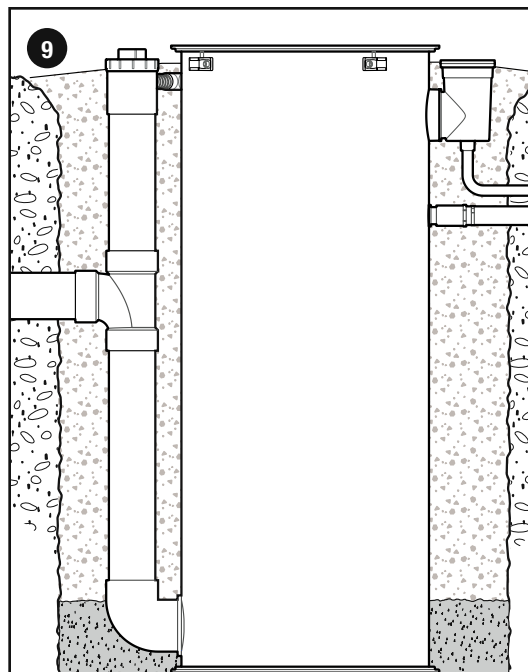

Complete the final backfill and secure the basin lid.