

AdvanTex® AX20 2 Pod Mode 1A

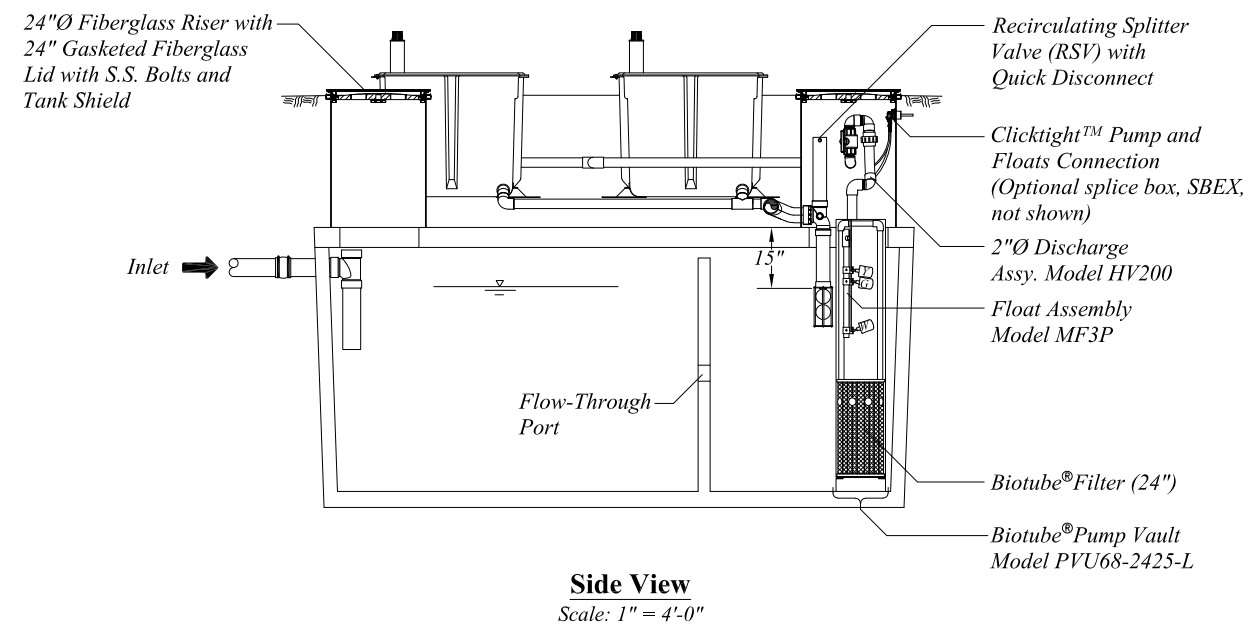
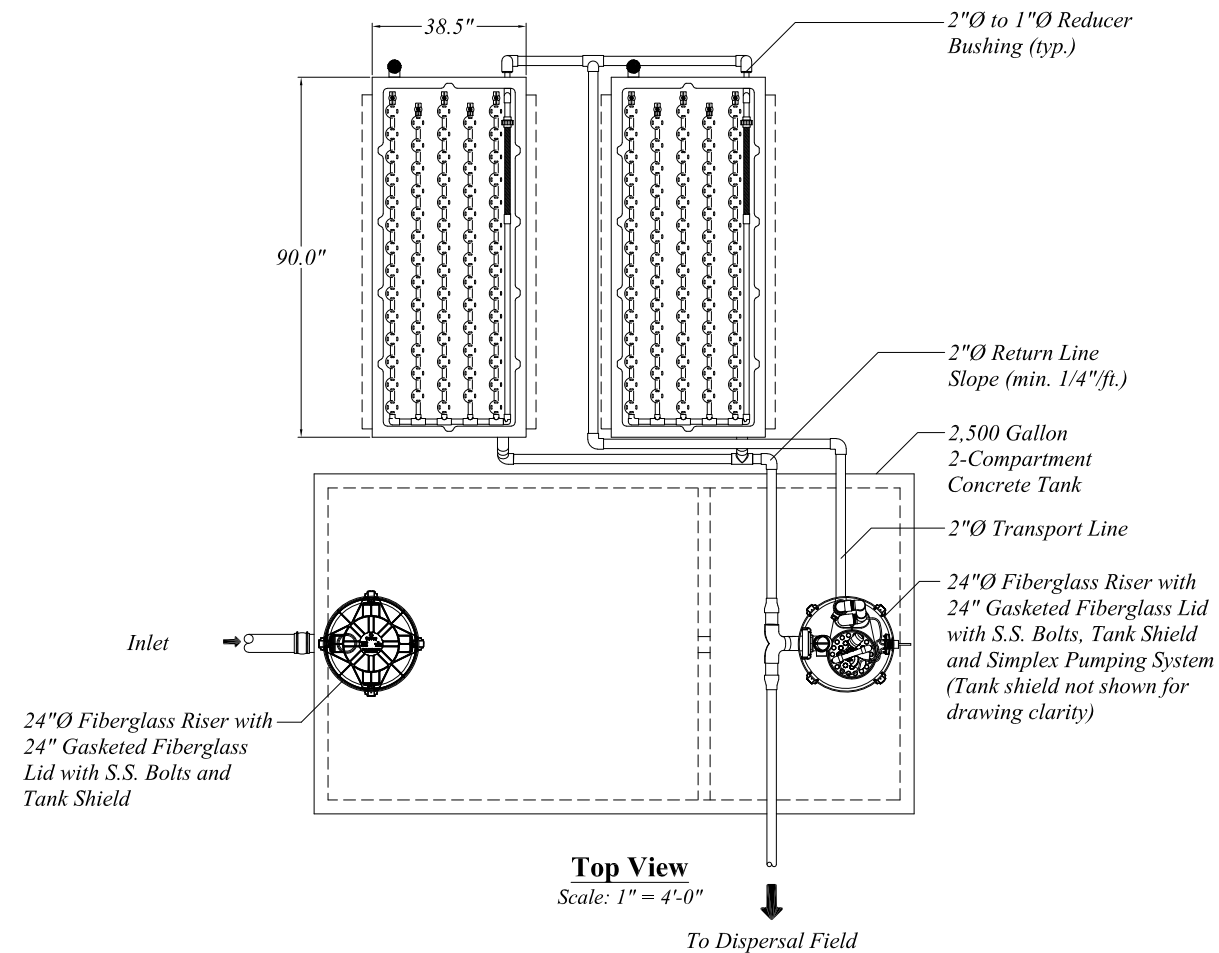

Float Functions	
Y	High Level Alarm
G	Override Timer ON/OFF
W	LLA/RO

Processing Tank Sizing			
Bedrooms	Occupants (maximum)	2-Compartment Processing Tank (min. gallons)	*Single Compartment Septic Tank (min. gallons)
5	10	2,500	1,500
6	12	3,000	2,000

* Alternative single compartment septic tank must be followed by a 1,000 gallon (min.) recirculation tank.

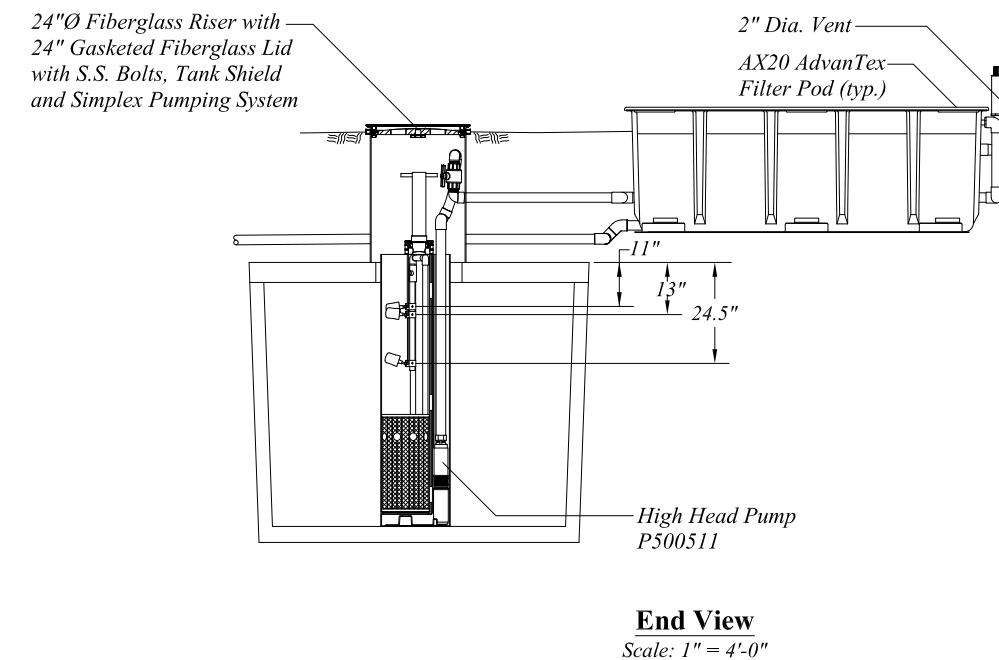
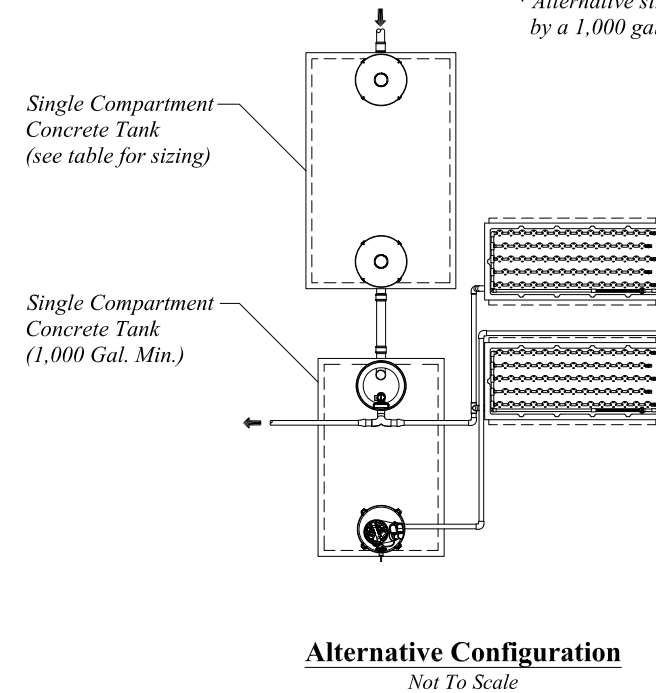

Design Notes

For residential strength waste up to 6 bedrooms. Applications greater than 6 bedrooms requires a design review by Orenco.

Installation to be performed by an AdvanTex Authorized Installer only.

Start-up and service to be performed by an AdvanTex Authorized Service Provider only.



© Orenco Systems, Inc.
Portions or all of this Proposed System Configuration Drawing, as appropriate, may be reproduced and integrated into the site-specific layout and configuration of a system by its designer.

Disclaimer: This Proposed System Configuration Drawing is provided solely as a design aid and illustrates one possible configuration of a system that would comply with Orenco's design criteria for the requirements and/or specifications that have been communicated to Orenco (based on third-party standards testing protocols and performance reports, as applicable). Design decisions, including the actual layout and configuration of the system and its viability for the project, are at the sole discretion of the systems's designer.

AX20 2 Pod Mode 1A

Design Aid

Drawn By:	BAS	Scale:	1" = 4'-0"
Reviewed By:		Sheet:	1 OF 1
File Name:	NDW-ATX-BNDR-3.DWG	Rev:	6.0
		Date:	9/23/2022