

Float Switch Settings and Adjustments

Before You Begin

Part 1 of these instructions provides basic information on how to make initial float switch settings in the absence of guidance from site plans, specifications, or applicable regulations regarding dosing, surge, and reserve volumes. These instructions are specific to pump vaults and tanks of 1000gal (3758L) or greater volume, both single-compartment and two-compartment with shared liquid levels.

Part 2 of these instructions explains how to physically adjust the position of float switches on an Orenco float switch assembly. For information on float switch settings and adjustments for AdvanTex® systems (“recirc” float switch settings), see NIN-ATX-DA-1, [Float Switch and RSV Settings for Residential AdvanTex Systems Instructions](#).

All product and performance assertions are based on proper design, installation, operation, and maintenance according to Orenco’s current published documentation.

Part 1. Guidelines for Initial Float Switch Settings

Float switch settings are the vertical distances from a common point of reference on the tank’s outside top to the set screw on the collar of individual float switches. They are used to control alarms and pump operations. Float switch settings are typically based on the needed or required volumes for the corresponding functions operated by the control panel, such as initiating a pumping event, engaging a timer, or triggering an alarm.

In the absence of guidance from site plans, specifications, or applicable regulations, Orenco recommends the following initial float switch settings for the systems listed in these instructions. Once you’ve determined the dose volume or timer settings, it is important to assess the necessary volumes between the float switches and adjust them accordingly.

Single-Pump (Simplex) Systems, Demand-Dose

- ❶ **High-Level Alarm:** Set at the same elevation as the tank inlet’s invert.
- ❷ **Pump On or Pump On/Off:** Set 2in (51mm) below the High-Level Alarm.
- ❸ **Pump Off (if used):** Set 2½in (64mm) below the switch above it.
 - Set this switch at least 5in (127mm) above the top of the filter cartridge if a Redundant Off/Low-Level Alarm (R/O) is used. If an R/O float switch is not used, set this switch at least 3in (76mm) above the top of the filter cartridge.
- ❹ **Redundant Off/Low-Level Alarm (if used):** Set at least 2in (51mm) below the switch above it.
 - Set this switch at least 3in (76mm) above the top of the filter cartridge.
 - Make sure this float switch is above the pump’s minimum liquid level.

Single-Pump (Simplex) Systems, Timed-Dose

- ❶ **High-Level Alarm or High-Level Alarm/Timer Override:** Set at the same elevation as the tank inlet’s invert.
- ❷ **Timer Override or Timer On/Off (if used):** Set 2in (51mm) below the High-Level Alarm.

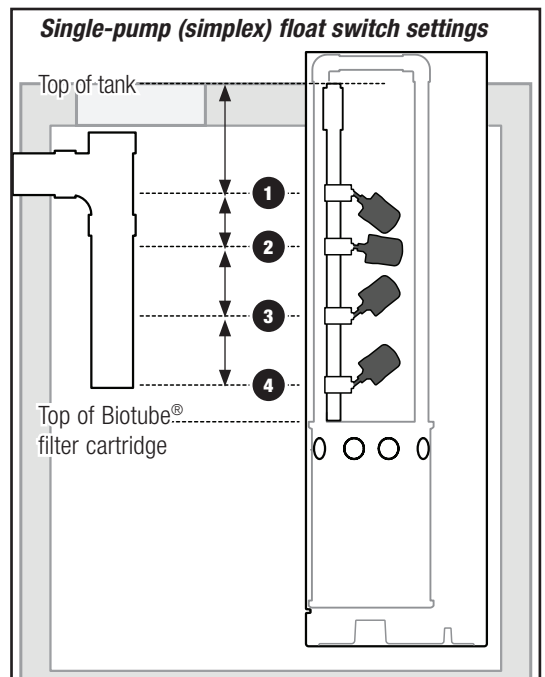
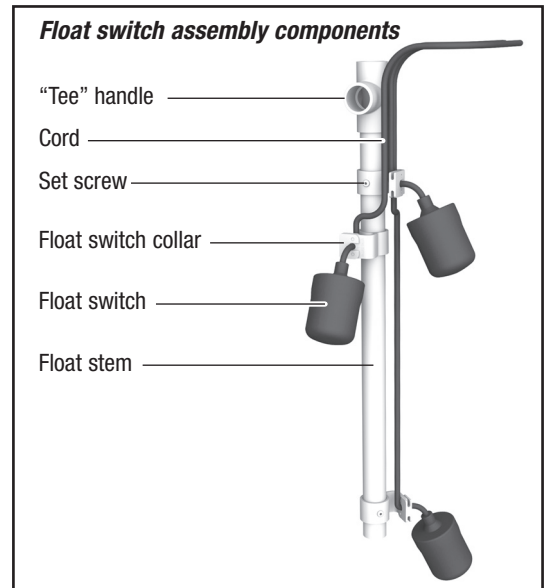

Single-Pump (Simplex) Systems, Timed-Dose, cont.

- ③ **Timer On/Off:** Set at the distance below the override float switch that equals the average daily flow for the system.
 - Determine the average day flow for the system.
 - Determine the gallons per inch (liters per mm) for the tank or basin.
 - Divide the average daily flow by gallons per inch or liters per mm of the tank chamber or basin to determine the necessary distance from the Timer On/Off to the float switch above it.
 - Set this switch at least 4½in (114mm) above the top of the filter cartridge if a Redundant Off/Low-Level Alarm (R/O) is used. If an R/O float switch is not used, set this at least 3in (76mm) above the top of the filter cartridge.
- ④ **Redundant Off/Low-Level Alarm (if used):** Set 3in (76mm) below the switch above it.
 - Set this switch at least 3in (76mm) above the top of the filter cartridge.
 - Make sure this float switch is above the pump's minimum liquid level.

Two-Pump (Duplex) Systems, Demand-Dose

- ① **High-Level Alarm or High-Level Alarm/Lag Pump Enable:** Set at the same elevation as the tank inlet's invert.
- ② **Lag Pump Enable (if used):** Set 2in (51mm) below the switch above it.
- ③ **Lead Pump On:** Set 2in (51mm) below the switch above it.
- ④ **Pumps Off:** Set 1½in (38mm) below the switch above it.
 - Set this switch at least 5in above the top of the filter cartridge if a Redundant Off/Low-Level Alarm (R/O) is used. If an R/O float switch is not used, set this switch at least 3in (76mm) above the top of the filter cartridge.
- ⑤ **Redundant Off/Low-Level Alarm (if used):** Set 3in (76mm) below the switch above it.
 - Set this switch at least 3in (76mm) above the top of the filter cartridge.
 - Make sure this float switch is above the pump's minimum liquid level.

Two-Pump (Duplex) Systems, Timed-Dose

- ① **High-Level Alarm or High-Level Alarm/Lag Pump Enable:** Set at the same elevation as the tank inlet's invert.
- ② **Lag Pump Enable (if used):** Set 2in (51mm) below the switch above it.
- ③ **Timer Override:** Set 2in (51mm) below the switch above it.

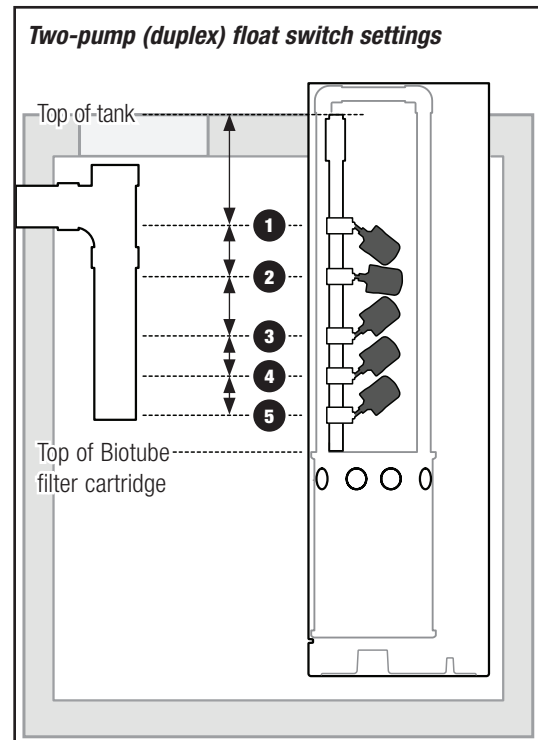

Two-Pump (Duplex) Systems, Timed-Dose, cont.

- 4 **Timer On/Off:** Set at the distance below the override float switch that equals the average daily flow for the system.
 - Determine the average day flow for the system.
 - Determine the gallons per inch (liters per millimeter) for the tank or basin.
 - Divide the average daily flow by gallons per inch or liters per millimeter of the tank chamber or basin to determine the necessary distance from the Timer On/Off to the float switch above it.
 - Set this switch at least 4½in (114mm) above the top of the filter cartridge if a Redundant Off/Low-Level Alarm (R/O) is used. If an R/O float switch is not used, set this switch at least 3in (76mm) above the top of the filter cartridge.
- 5 **Redundant Off/Low-Level Alarm (in 4-switch systems):** Set 2½in (64mm) below the switch above it.
 - Set this switch at least 3in (76mm) above the top of the filter cartridge.
 - Make sure this float switch is above the pump's minimum liquid level.

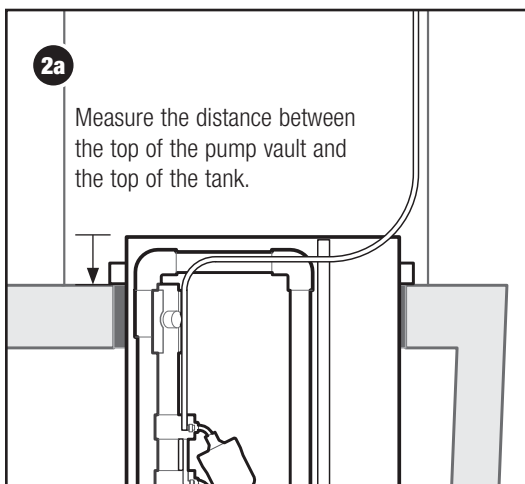
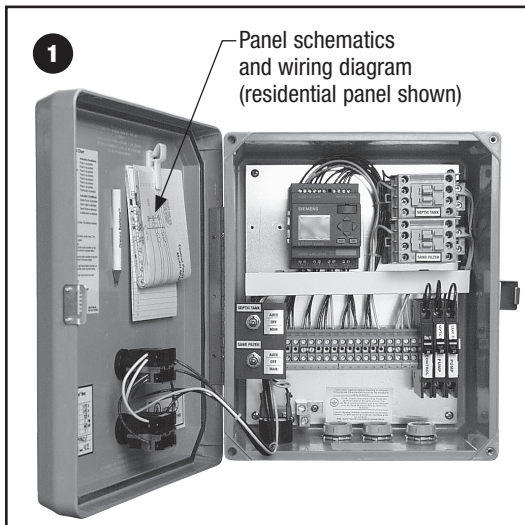

Part 2. Adjusting Float Switch Settings

Step 1. Check Float Switch Assembly

Check the assembly against the system's wiring diagram (located in the control panel).

- If you can't locate the wiring diagram, contact Orenco for a replacement.
- For information on 3-pump or 4-pump systems, contact your distributor or Orenco.

Step 2. Verify Float Switch Settings

Step 2a: Measure the distance between the top of the pump vault and the top of the tank. Note this distance for use in the following steps.

- Use the top of the tank as the common reference point for setting float switches.

Step 2b: Starting at the top of the pump vault, measure down along the stem of the float switch assembly the same distance measured in the previous step.

Step 2c: Mark that distance on the float switch assembly stem.

- If measured and marked correctly, this mark should be level with the outside top of the tank, and you can use it to measure float switch settings with the float switch assembly removed.

Step 2. Verify Float Switch Settings, cont.

Step 2d: Remove the float switch assembly from the bracket.

Step 2e: Use the plans/specifications or applicable regulations and the reference mark on the stem to make sure the float switches are set correctly.

- If the settings don't match the plans, specifications, or applicable regulations, adjust the settings accordingly.
- If there are no plans, specifications, or applicable regulations, use the general guidelines in this document to determine initial float switch settings for the system.
- For further assistance, call your distributor or Orenco.

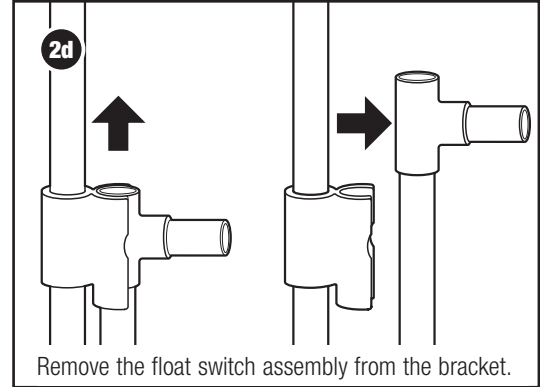

Step 3. Adjust Float Switch Settings

Step 3a: Loosen the set screw(s) on the float switch collar(s).

- Don't back the set screws completely out of the float switch collars.

Step 3b: Adjust the float switch collar(s) vertically to match the settings provided on the plans or in applicable regulations.

- For existing systems, vertically adjust the collar as necessary to meet discharge volume needs as described in the plans/specifications or applicable regulations.

Step 3c: Check for vertical and horizontal clearance between the float switches and between the float switches and the walls of the vault or basin.

- Move each float switch through its range of vertical motion.
- The float switches shouldn't interfere with one another during this check.

Step 3d: If the float switches interfere with another, adjust the collar horizontally until the float switch is clear of the float switch(es) above or below it.

Step 3e: When the float switch(es) are adjusted and have vertical and horizontal clearance, tighten the set screw(s).

Step 3f: Reinstall the float switch assembly back into the float switch bracket and use the reference mark to set the float switch assembly at the correct distance from the outside top of the tank.

- Make sure that the walls of the vault or basin don't interfere with the movements of the float switches. If they do, remove the float switches, and readjust their horizontal clearances.

