

Biotube[®] 60Hz LOS Pump Package[™]

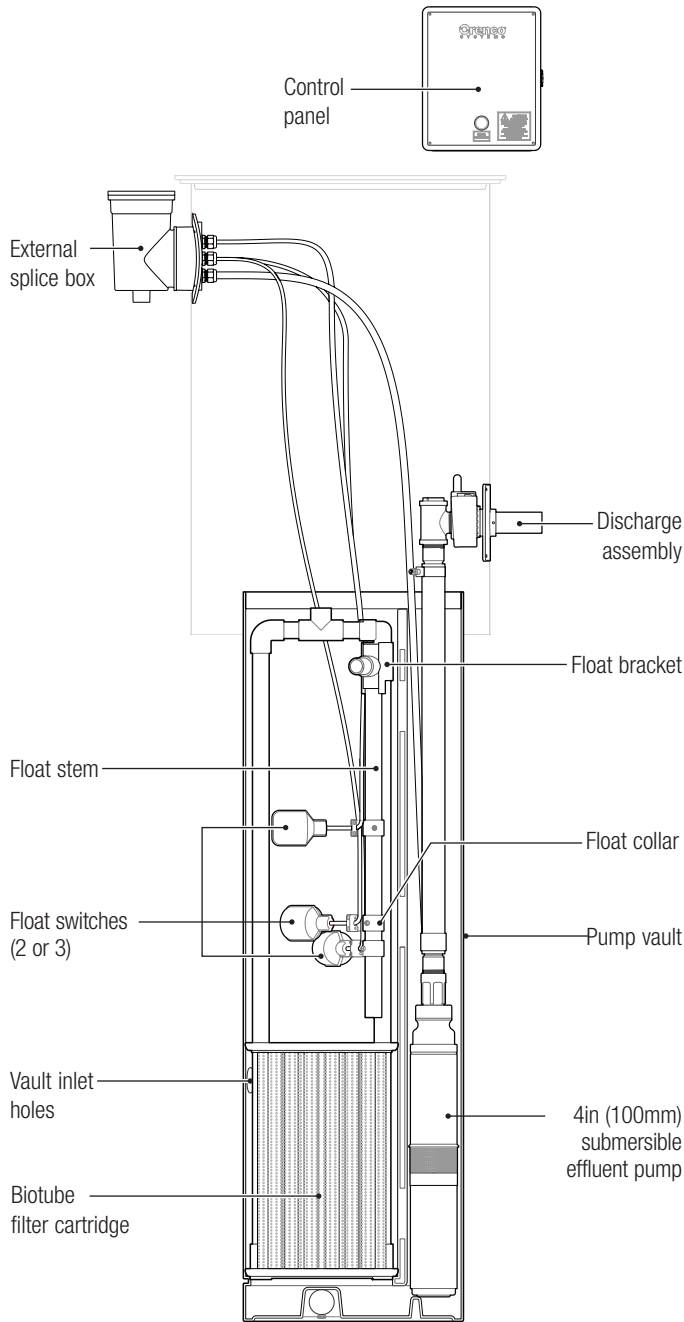

Biotube 60Hz LOS Pump Package

Applications

The Biotube LOS Pump Package is designed to filter and pump effluent from a one- or two-compartment septic tank to a liquid-only sewer (aka "pressure sewer") system.

General

Orenco's Biotube LOS Pump Package makes it simple to select and install the correct pump and controls package. Its patented Biotube pump vault technology eliminates the need for a separate septic tank and pump tank. The pump vault also allows removal of the effluent filter for cleaning with no need to remove the pump vault or pump, which simplifies servicing.

For more information on specific LOS components, see the following Orenco technical documents:

- *S-Series Simplex Control Panels* (NTD-CP-S-1)
- *MVP Simplex Control Panel* (NTD-CP-MVP-1)
- *External Splice Box* (NTD-SBEX-1)
- *Splice Boxes* (NTD-SB-SB-1)
- *HDA Discharge Assemblies* (NTD-HDA-1)
- *Discharge Assemblies* (NTD-HV-HV-1)
- *PF-Series Submersible Effluent Pumps: 1-Phase, 60-Hz, 4-inch (100-mm)* (NTD-PU-PF-1)
- *Universal Biotube Pump Vaults* (NTD-PVU-1)
- *PVP-Series Biotube Pump Vaults* (NTD-PVU-3)
- *PV-Series Biotube Pump Vaults* (NTD-PVU-2)

Product Code Diagrams

Standard Product Code:



Discharge assembly; details:

- HD1 = HDA24125FCASLC-FS; field-set, 1.25in hose, flow control, P01 (PF100511CV) pump only
- HD2 = HDA24125ASLC-FS; field-set, 1.25in hose, P01 (PF100511CV) pump only
- HD3 = HDA24125CFCASLC-FS; field-set, 1.25in hose, check valve, flow control, 10gpm pumps only
- HD4 = HDA24125CASLC-FS; field-set, 1.25in hose, check valve, 10, 20, or 30gpm pumps
- SD1 = HV100BCFCX; field-cut, 1in PVC, ball valve, check valve, flow control, 10gpm pumps only
- SD2 = HV100BCX; field-cut, 1in PVC, ball valve, check valve, 10 or 20gpm pumps
- CW1 = HV100BCFCX + HVCW100-KIT; field-set, 1in PVC, ball valve, check valve, flow control, 10gpm pumps only
- CW2 = HV100BCX + HVCW100-KIT; field-set, 1in PVC, ball valve, check valve, 10 or 20gpm pumps
- DB1 = HV100B-DB; field-set, ball valve, drainback, 10 or 20gpm pumps

Pump vault height, in (mm), for 18in (450mm) diameter filter:

- 48 = 48 (1219) PVU-Series 60 = 60 (1524) PVP-Series
- 57 = 57 (1448) PVU-Series 55 = 55 (1397) PV-Series
- 68 = 68 (1727) PVU-Series

Splice box options:

- SB = Internal splice box
- SX = External splice box

Float switch & pump cord lengths, ft (m):

- 10 = 10 (3)
- 20 = 20 (6)

Control panel; float switches:

- S11 = S1; 3P
- S12 = S1ETMCT; 3P
- S13 = S1HR; 2P
- S16 = S1RO; 3PN
- S19 = S1ROMTSGR-NC; 3PN

Submersible effluent pump model; details:

- P01 = PF100511CV; 10gpm (0.6L/sec), 0.50hp (0.37kW), 120V, for HD1 and HD2 only
- P02 = PF100511; 10gpm (0.6L/sec), 0.50hp (0.37kW), 120V
- P03 = PF100512; 10gpm (0.6L/sec), 0.50hp (0.37kW), 240V

Biotube® LOS Pump Package™

Project-Specific Product Code:

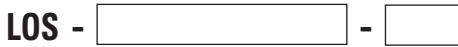

Project name

State or province

Biotube® LOS Pump Package™