

Orenco Tank Shield™

Applications

Orenco's Tank Shield is a secondary safety barrier, designed to prevent unintended entry and accidental falls into tanks and pump basins. It can be installed in a new or existing tank access riser or pump basin. Tank Shield is compatible with Orenco's 24in (600mm) and 30in (750mm) FRP pipe, as well as 24in (600mm) Ultra Rib™ pipe.

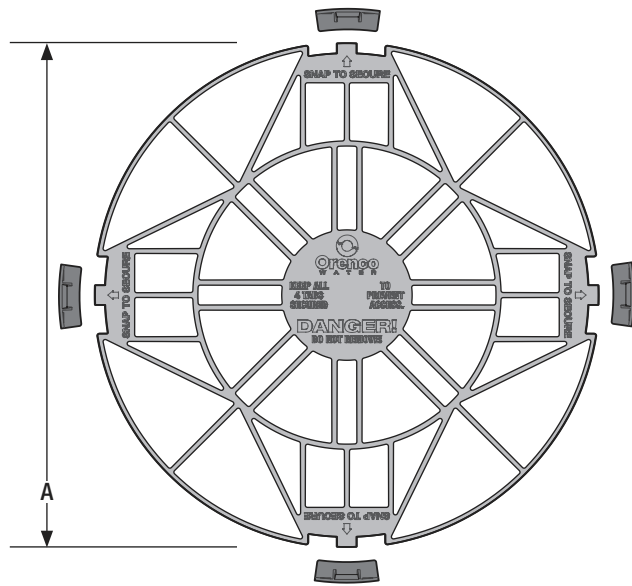

RTS30 Tank Shield, top view (shown with mounting brackets)

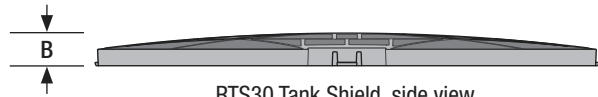

RTS30 Tank Shield, side view

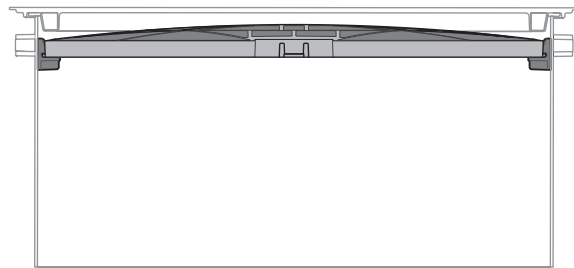

Orenco's Tank Shield locks securely into mounting brackets without the need for additional bolts or screws.

General

Orenco's Tank Shield is capable of supporting a load of up to 250lbs (113kg), providing more security and safety for tanks and pump basins than access riser lids alone. It locks securely into mounting brackets that are attached to the access riser with stainless steel hardware, eliminating the need for additional bolts or screws. It can be installed over pumping equipment.

Tank Shield is molded of co-polymer polypropylene (CPPP) for exceptional durability. Tank Shield mounting brackets and hardware can also be ordered individually (RTS-MB). For cold weather applications, optional insulation is available.

Standard Models

RTS24-KIT, RTS30-KIT

Product Code Diagram

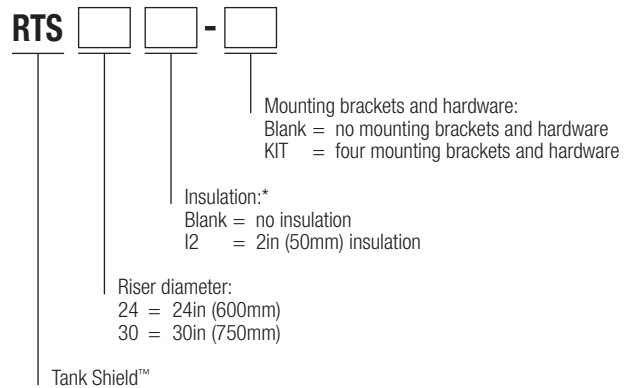

* Insulation has an R-value of 10 per 2in increment (RSI 1.8 per 50mm)

Materials of Construction

Tank Shield	Co-polymer polypropylene
Brackets	ABS
Hardware	Stainless steel
Insulation, optional	Closed-cell foam

Specifications

Model	RTS24	RTS30
A Diameter, in (mm)	23 (584)	29 (738)
B Height, in (mm)	1.5 (38)	1.9 (48)
Load rating, lbs (kg)	250 (113)	250 (113)
Insulation R-value (RSI value)	10 (1.8)	10 (1.8)