

Float Switch Assemblies

Applications

Float switches are used to signal liquid level positions for alarm and pump control applications. Orenco float switch assemblies can be mounted in pump vaults, effluent screens, pump basins, and risers.

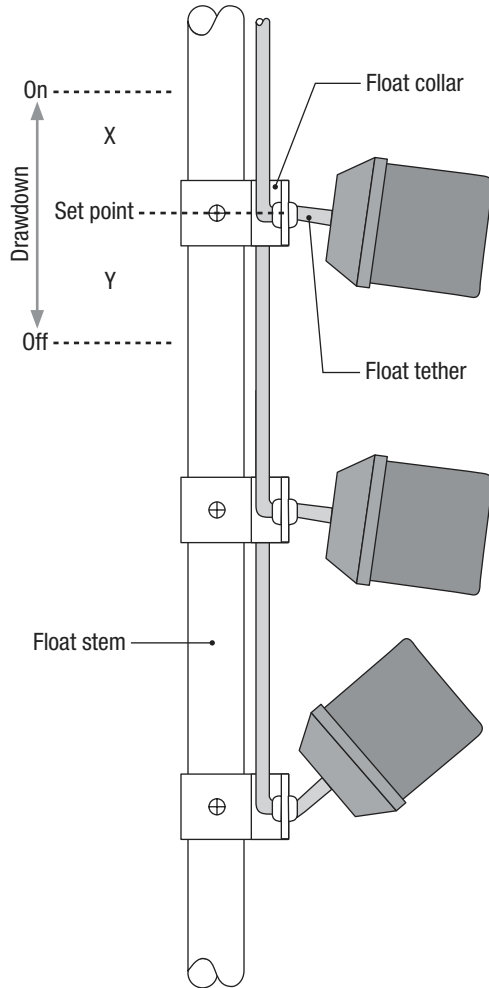

The “On” and “Off” positions shown describe normally open float switches. “On and “Off” positions are reversed for normally closed float switches.

General

All models except “J” are UL listed and CSA certified for use in water or sewage; “J” switches are a CSA-certified direct alternative to “P” switches. Non-mercury float switches (models B, C, J, N, and P) are used where components containing mercury are prohibited.

Float switches are typically ordered in assemblies that include one or more switches mounted on a 1 in PVC float stem. ABS float collars are used to provide secure mounting that is easily adjustable.

Normally-open “P” float switches have a blue cap for easy identification; normally-closed “N” float switches have a red cap.

Standard Models

B, C, G, J, N, P

Product Code Diagram

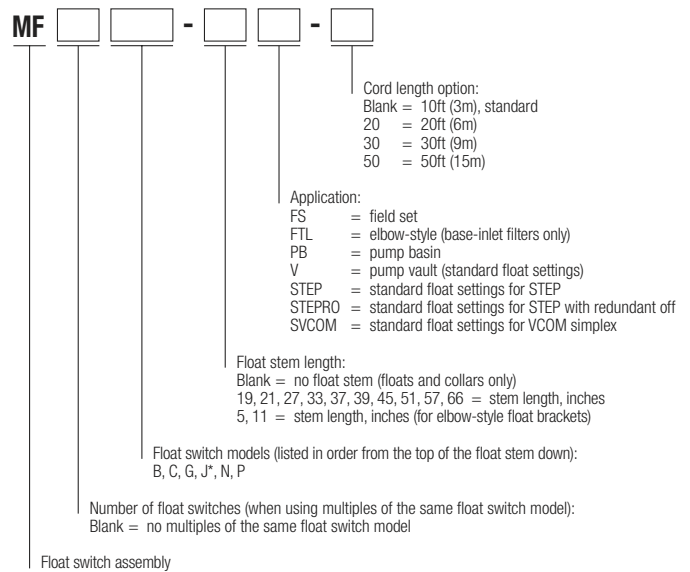

* CSA-certified, direct alternative to “P” float switch.

Note

When ordering float switch assemblies, remember to list float switches from the top of the float stem down. An “MFPBN-” product code indicates one “P” switch at the top of the stem, one “B” in the middle of the stem, and one “N” switch at the bottom of the stem; an “MF2PN-” indicates “P” switches at the top and middle of the stem, and one “N” switch at the bottom of the stem.

Signal- and Motor-Rated Float Switch Matrix

Model	State ¹	Type	IR ²	Volts	Amps	hp	Tether	X	Y	Drawdown ³
Signal-rated mechanical float switches⁴ (for control switch applications)										
P^a	Normally open	Mechanical	Yes	n/a	n/a	n/a	2.00in	1.50in	0.50in	2.00in
J^a	Normally open	Mechanical	Yes	n/a	n/a	n/a	2.00in	2.00in	0.10in	2.10in
N^a	Normally closed	Mechanical	Yes	n/a	n/a	n/a	2.00in	1.50in	0.50in	2.00in
Motor-rated float switches⁴ (for pump switch applications)										
B	Normally open	Mechanical	No	120V	13A	1/2hp	2.00in ^b	2.50in	1.50in	4.00in
				240V	13A	1hp	3.00in	3.00in	1.50in	4.50in
							4.00in	3.25in	1.50in	4.75in
C	Normally open	Mechanical	No	120V	13A	1/2hp	2.00in	3.00in	2.50in	5.50in
				240V	15A	2hp	3.00in ^b	3.50in	3.00in	6.50in
							4.00in	4.00in	3.50in	7.50in
							5.00in	4.50in	4.00in	8.50in
							6.00in	5.25in	4.25in	9.50in
G	Normally open	Mercury	Yes	120V	15A	3/4hp	2.00in	1.50in	3.00in	4.50in
				240V	15A	2hp	3.00in ^b	1.75in	3.00in	4.75in
							4.00in	2.00in	3.50in	5.50in

a. Suitable for use with VCOM and MVP

b. Standard tether length

Notes

¹ State: normally open or normally closed

Float switches have an internal contact. The terms "normally open" (N/O) and "normally closed" (N/C) refer to the default state of the float switch contact. The default state refers to the contact positions in the float switch when it is resting (down). A normally open float switch has an open contact (off) in the down position, and a normally closed float switch has a closed contact (on) in the down position. Different panel functions require different types of float switches. Most applications require float switches that are normally open. One notable exception is the redundant off and low-level alarm function that requires a normally closed float switch, except with MVP and VCOM panels.

² IR (intrinsically safe relay)

Indicates that the float switch is approved for use with intrinsically safe, Class I, Division 1 applications, where reliable float switch operation with very low current is required.

³ Drawdown

Drawdown (in inches) refers to the difference in liquid level between a float switch's activation and deactivation points. Drawdown can be altered by adjusting the tether length of the float switch cord. When selecting float switches, keep in mind that any float switch that can directly start and stop a pump (one that has no motor contactor in the control panel) should have a drawdown capability, to avoid rapid cycling of the pump.

⁴ Signal-rated or motor-rated

Every float switch has a maximum amount of current it can handle. Exceeding these limits may cause premature failure. Signal-rated or "control" float switches are used to activate pump control panels and alarms. Only low-amperage signals pass through these switches, hence the switch is "signal-rated." All Orenco panels that use motor contactors can use signal-rated float switches. In some systems, a float switch is used to directly start and stop a pump. In this application, the current running the pump passes through the switch as well, so the switch must be "motor-rated." In most instances, a motor-rated float switch can be used as a signal-rated float switch.